



Soundpond
Technical performance



Fujian Safetech Protection Co.,LTD

NAME LIST OF NON-MEDICAL USE FACE MASKS COMPANIES WITH
CERTIFICATION/AUTHORIZATION FROM OTHER COUNTRIES

FFP2 PROTECTIVE MASK

SOUNDPOND SAFETECH MANUFACTURING BASE



100,000 CLASS CLEAN WORKSHOP

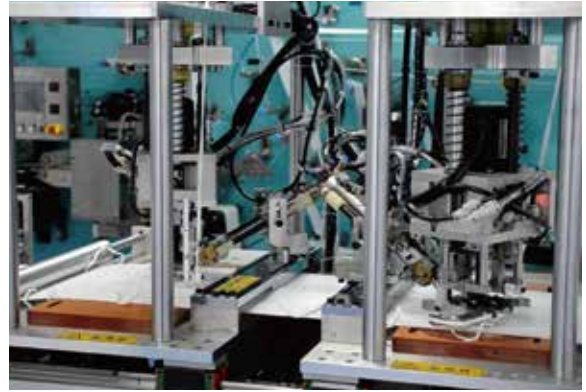

TESTING CENTER





Located in China's southern-east coast, Fujian safetech protection Co.,LTD. has got our own large production facilities producing workwear, functional wear, rainwear, and uniforms.

Established in 2009, our company is a professional manufacturer engaged in the research, development, production, sales and service of medical instruments.

Our main products are disposable protective coverall , isolation gown, surgical gown, disposable shoes cover,safety glasses ,KN95 and so on.

Dedicated to strict quality control and thoughtful customer service, our experienced staff members are always available to discuss your requirements and ensure full customer satisfaction. In recent years, our company has introduced a series of advanced equipment.

In addition, we have attained FDA, CE and ISO9001 certificates. Selling well in all cities and provinces around China, our products are also exported to clients in such countries and regions as Africa, Europe and America.

We also welcome OEM and ODM orders.Whether selecting a current product from our catalog or seeking engineering assistance for your application, you can talk to our customer service center about your sourcing requirements.

PROTECTIVE MASK

GB2626-2019

FIVE-LAYER
THREE-DIMENSIONAL

CE 0598 FFP2 NR
EN 149:2001+A1:2009



MULTI-LAYERS PROTECTION



FIT-TO-FACE DESIGN



FOLDABLE



SOFT EARHOOK



TEMPERATURE RANGE OF STORING
-30° C TO +70° C



MAXIMUM RELATIVITY HUMIDITY OF STORING
80% AND MORE



DAMAGE DISABLED



2 YEARS (USABLE LIFE)



SEE INFORMATION SUPPLIED BY THE MANUFACTURER

FILTRATION EFFICIENCY

≥ 95%

KN95/FFP2 PROTECTIVE MASK—WITH VALVE (HEAD BAND WITH ULTRASONIC)

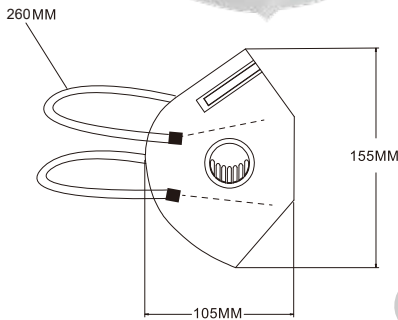

Five-layers filter structure, high filtration efficiency, dust filter rate 95%, anti - particulate dust and pollen. Skin-friendly surface non-woven fabric has good water absorption function, the outer non-woven fabric has good water resistance and can continuously resist pollution. Inner nose clips KN95 protective masks are widely used in factories, electronic, instrumentation, food and outdoor places.

PRODUCT PARAMETERS			
Brand	Soundpond safetech	Color	○
Item number	SP-2020B	Layer	Five-layer
Material	Non-woven fabric, melt-blown fabric	Function	Anti-fog Anti-dust Anti-spray
Storage	Cool Ventilation Dry	Package	Individual package

PACKAGE SIZE:

PACKAGING 1:

Packaging 1:
Qty/Bag: 5pcs
Bag Size: 16X22CM
Bags/Ctn: 90 bags



PACKAGING 2:

Packaging 2:
Qty/Bag: 10pcs
Bag Size: 18X28CM
Bags/Ctn: 60 bags



PACKAGING 4:

Packaging 3:
Qty/Box: 25pcs
Box Size: 12.5*12*19CM
Boxes/Ctn: 16 Boxes



BUSINESS LICENSE



This image shows a Chinese Business License (营业执照) for Fujian safetech protection co., ltd. The license is issued by the Minhou County Administration Center. It includes the company name, registered capital, date of establishment, and business scope. A QR code is provided for verification, and a red circular official seal is stamped on the document.

Unified social credit code: 913501217947522494

Business license: 营业执照

Company name: Fujian safetech protection co., ltd

Type: limited liability company (private own)

Legal representative: Liu Yulin

Registered capital & Millions USD: 800,000,000

Date of establishment: 2006-Oct-08

Term of operation: 2006-Oct-08 to 2056-Oct-07

Address: Tieling Industrial concentration area, Minhou county

Business scope: Production for all kinds of woven, knitted clothing, fire fighter clothing, bags and suitcases, hats, gloves and other related fabrics; accessories; Wholesale and sale of gold ornaments; Manufacturing of medical protective masks; Manufacturing of other medical equipment and apparatus not specified; Manufacturing of sanitary materials and medical supplies; Sales of medical devices; Nonwovens fabric manufacturing; Other woven clothing manufacturing; Manufacture of other knitted or crocheted garments; Wholesale of toilet appliances; Wholesale of groceries; Internet retail; Import and export of goods or technologies

Red Seal: 福建省市场监督管理局 (Fujian Provincial Market Supervision Administration)

QR Code: 扫描二维码 (Scan QR code)

Official Seal: 福建省市场监督管理局 (Fujian Provincial Market Supervision Administration)

Watermark: safetech.com

MEDICAL DEVICE PRODUCTION LICENSE

Medical device production license
医疗器械生产许可证

License no.: Bureau of Fujian medical device supervision #20200618

许可证编号: 闽药监械生产许20200618号

企业名称: 福建顺邦防护科技有限公司
Company name: Fujian safetech protection co.,ltd

生产地址: 福州市闽侯县荆溪镇铁岭工业园一期九号东楼6号1号楼1层、2号楼9号楼1层
Address: Tieling Industrial zone, Zone 1,Block 9Jingxi town, Minhou county, Fujian province P.R. China.

法定代表人: 刘玉林

生产范围: 一类、二类医护人员防护用品***

Legal representative: Liu Yulin

Production scope: class II 14-14 protective equipment for medical staff

企业负责人: 刘玉林
Business owner: Liu Yulin

License issuing department: Drug administration of Fujian

住所: 闽侯县铁岭工业集中区
Address: Tieling industrial concentration area,Minhou county

发证部门: 福建省药品监督管理局
福建省委省政府
福建省药品监督管理局

有效期至: 至 2025 年 06 月 03 日
Valid to :2025-JUNE-03

发证日期: 2020 年 06 月 04 日
Date of Issue:2020-JUNE-04



RECORDAL REGISTER BOOK OF INTERNATIONAL TRADER

对外贸易经营者备案登记表

统一社会信用代码: 91350121793752241N

备案登记表编号: 03493846

进出口企业代码: _____

经营者中文名称	福建顺邦防护科技有限公司		
经营者英文名称	FUJIAN SAFETECH PROTECTION CO.,LTD.		
组织机构代码	_____	经营者类型 (由备案登记机关填写)	有限责任公司
住 所	闽侯县铁岭工业集中区		
经营场所 (中文)	闽侯县铁岭工业集中区		
经营场所 (英文)	Tieling Industrial Concentration Area, Minhou County		
联系电话	13799990797	联系传真	_____
邮政编码	350101	电子邮箱	linlinganny@163.com
工商登记注册日期	2006-10-8	工商登记注册号	_____

依法办理工商登记的企业还须填写以下内容

企业法定代表人姓名	刘玉林	有效证件号	350102196309100516
注册资金	陆仟陆佰肆拾万元		(折美元)

依法办理工商登记的外国 (地区) 企业或个体工商户 (独资经营者) 还须填写以下内容

企业法定代表人 / 个体工商户负责人姓名		有效证件号	
企业资产 / 个人财产			(折美元)

备注	已完成原产地申请人备案, 请到检验检疫机构/贸促会办理原产地证
----	---------------------------------

填表前请认真阅读背面的条款, 并由企业法定代表人或个体工商户负责人签字, 盖章。



2020

04 年 月 日

NAME LIST OF NON-MEDICAL USE FACE MASKS COMPANIES WITH CERTIFICATION/AUTHORIZATION FROM OTHER COUNTRIES



中国医药保健品进出口商会
服务产业链 | 助力国际化

English

[首页](#) |
 [关于商会](#) |
 [新闻中心](#) |
 [行业服务](#) |
 [权威发布](#) |
 [商会会刊](#) |
 [企业风采](#) |
 [会员之家](#) |
 [加入商会](#)

新闻中心 > 通知公告

动态更新：取得国外标准认证或注册的非医用口罩生产企业清单

2020年10月17日 中国医药保健品进出口商会

推荐阅读

序号	生产企业	统一社会信用代码	国外注册认证情况
882	福建顺邦防护科技有限公司 Fujian Safetech Protection Co.,Ltd	91350121793752244N	欧盟CE
883	深圳市维珍妮医疗科技有限公司 Shenzhen Regina Miracle Medical Technology Co., Ltd.	91440300MA5G811Y9B	欧盟CE
884	深圳市大生圆医疗器械有限公司 Shenzhen Da Sheng Yuan Medical Equipments Company Limited	91440300MA5G45J4X1	欧盟CE
885	易纬(广东)医疗生物科技有限公司 Everlasting(Guangdong) Medical&Biological Technology Co.,Ltd.	91441802MA54CK9WGT	欧盟CE
886	惠州市中德医疗科技有限公司	91441302MA4UH-HPTZT	欧盟CE

动态更新：取得国外标准认证或注册的非医用口罩生产企业清单...
 医药商会荣获商务部抗击新冠肺炎疫情工作特别贡献奖...
 关于邀请参加2020防疫物资精品展暨医疗器械国际会...
 国内具备欧盟 (EN149/14683) 检测能力的检测机构...
 克旗现场今取双胜利 | “战时” 担当当 专业防疫区 谱...
 ...
 有关表述
 社口“抗击疫情经验国际...
 一行赴防疫物资生产企业北...
 海外商医审核交流视频会议
 商会党组织负责人接受央视...

2020年10月17日 中国医药保健品进出口商会

取得国外标准认证或注册的非医用口罩生产企业清单

动态更新：2020年10月16日下载

序号	生产企业	统一社会信用代码	国外注册认证情况
882	福建顺邦防护科技有限公司 Fujian Safetech Protection Co.,Ltd	91350121793752244N	欧盟CE
883	深圳市维珍妮医疗科技有限公司 Shenzhen Regina Miracle Medical Technology Co., Ltd.	91440300MA5G811Y9B	欧盟CE
884	深圳市大生圆医疗器械有限公司 Shenzhen Da Sheng Yuan Medical Equipments Company	91440300MA5G45J4X1	欧盟CE



FOOD AND DRUG ADMINISTRATION

Classification Name:FACE MASK (EXCEPT N95 RESPIRATOR) FOR GENERAL PUBLIC/HEALTHCARE PERSONNEL PER IIE GUIDANCE

Registered Establishment Name:FUJIAN SAFETECH PROTECTION CO., LTD

Registered Establishment Number: **3016666730**

Owner/Operator:Fujian Safetech Protection Co Ltd

Owner/Operator Number: **10063359**

Establishment Operations:Manufacturer



U.S. Department of Health & Human Services

Follow FDA | En Español

U.S. FOOD & DRUG ADMINISTRATION

Home | Food | Drugs | Medical Devices | Radiation-Emitting Products | Vaccines, Blood & Biologics | Animal & Veterinary | Cosmetics | Tobacco Products

Establishment Registration & Device Listing

1 result found for Owner Operator Number : 10063359

Establishment Name	Registration Number	Current Registration Yr
FUJIAN SAFETECH PROTECTION CO., LTD CHINA	3016666730	2020
<ul style="list-style-type: none"> Suit, Surgical Face Mask (Except N95 Respirator) For General Public/Healthcare Personnel Per Iie Guidance Non-Surgical Isolation Gown Respirator, Surgical - KN95 		Manufacturer

Can't find what you're looking for? [Try a new search](#)

Page Last Updated: 05/04/2020
 Note: If you need help accessing information in different file formats, see Instructions for Downloading View

Classification Name:	FACE MASK (EXCEPT N95 RESPIRATOR) FOR GENERAL PUBLIC/HEALTHCARE PERSONNEL PER IIE GUIDANCE
Product Code:	QKR
Device Class:	Not Classified
Registered Establishment Name:	FUJIAN SAFETECH PROTECTION CO., LTD
Registered Establishment Number:	3016666730
Owner/Operator:	Fujian Safetech Protection Co Ltd
Owner/Operator Number:	10063359
Establishment Operations:	Manufacturer

MODULE B, EU TYPE-EXAMINATION



EN 149:2001+A1:2009 FFP2NR



MODULE D



Certificate CN21/42153

The management system of

FUJIAN SAFETECH PROTECTION CO., LTD.

No.6 Road East, Tieling Industrial Zone, Zone 1, Block 9, Jingxi Town,
Minhou County, Fuzhou City, Fujian Province, P.R. China

has been assessed and certified as meeting the requirements of

Regulation (EU) 2016/425

Module D

For the following activities

Manufacture of FFP2 Protective Respirators
(Note: all products marked CE0598 must have a valid EU Type Examination Certificates issued under Module B or a valid EC type-examination certificate issued under Article 10 of the PPE Directive 89/686/EEC.)

This certificate is valid from 21 February 2021 until 20 February 2024
and remains valid subject to satisfactory surveillance audits.
Re certification audit due before 28 January 2024
Issue 1. Certified since 21 February 2021

Authorised by



SGS FIMKO OY, Notified Body 0598
Tukomatie 8, FI-00380 Helsinki, Finland
t +358 9 696 351 f +358 9 692 5474 www.sgs.com



FINAS
Finnish Accreditation Service
S003 (EN ISO/IEC 17065)

Page 1 of 1



This document is issued by the Company subject to its General Conditions of Certification Service accessible at www.sgs.com/terms_and_conditions.htm. Attention is drawn to the limitations of liability, indemnification and jurisdictional issues established therein. The authenticity of this document may be verified at http://www.sgs.com/service/clients_and_producer/certified-clients-directory. Any unauthorised alteration, forgery or falsification of the content or appearance of this document is unlawful and offenders may be prosecuted to the fullest extent of the law.

TEST REPORT-GB2626-2006

SGS MA CNAS 中国认可 测试机构 TESTING CNAS 1599

检测报告 编号 日期 第 1 页共 6 页
 Test Report No. SL520252571281TX Date: 2020-7-10 Page 1 of 6

下列样品由客户提供并确认: The following sample(s) was/were submitted and identified on behalf of the client as:

客户信息 Client information	委托单位: Consignor	福建斯耐德防护科技有限公司 FUJIAN SAFETECH PROTECTION CO., LTD
	委托单位地址: Consignor address	福建省福州市闽侯县青圃镇钢铁工业园一期九号路 6 号 NO.6 ROAD EAST, TIEJING INDUSTRIAL ZONE (1), JINGXI TOWN, MINHOU COUNTY, FUZHOU 350111, FUJIAN
样品信息 Sample information	样品描述: Sample Description	KN95 防护口罩(非医用), 无纺布, 熔喷布, 颜色为白色。 KN95 protective face mask (non-medical), non-woven/melt-blown in white.
	样品名称: style No.	SF2020
	生产厂家: Manufacturer	福建斯耐德防护科技有限公司 FUJIAN SAFETECH PROTECTION CO., LTD
	样品数量: Sample Quantity	1 包 One package
检测信息 Test information	检测日期: Sample Received Date	2020-05-13
	检测周期: Test Period	2020-05-13-2020-07-10
	检测报告: Document	详见检测报告 See test result page
	检测依据: Judgement	客户要求: GB 2626-2006 呼吸防护用品 过滤式过滤颗粒物呼吸器 requirement: GB 2626-2006 Respiratory protective equipment- Non-powered or purifying particle respirator
检测结果: Test Conclusion	本报告仅就提交的数据和样品判定, 不涉及检测方法。总页。 The report only give the test result and individual judgment, detail please see follow page.	

福建斯耐德防护科技有限公司
 SGS-CSTC Standards Technical Services (Shang) Co., Ltd
 批准人签署 Approved by:

曹小英 Ellen Cui
 (授权签字人 Authorized Signatory)
 测试数据仅供参考
 This test report refer only to the samples tested

SGS 检测报告 编号 日期 第 2 页共 6 页
 Test Report No. SL520252571281TX Date: 2020-7-10 Page 2 of 6

序号 No.	检测项目及测试方法 Test Item & Test Methods	单位 Unit	技术要求 Requirement	检测结果 Test Result	单独判定 Individual Judgment
1.	外观检查 Appearance (GB 2626-2006 6.1)	-	样品表面不得有裂纹、变形等影响使用的其他缺陷; 部件材料和结构应符合相交国家标准并尽可能朝向内侧。闻味和机械冲击, 头带应可调; 可更换式卡箍的扣带设计应可为可更换; 卡箍的扣带在佩戴时不应出现因受弯而影响视觉的情况; 过滤或吸附层应处理牢固且固定良好; 附件不可脱落、损坏和变形。 The sample surface shall be no damage, deformation and other other defects. The materials and structure of the sample shall be able to withstand normal use conditions and possible temperature, humidity. The mask band should be adjustable. After temperature, humidity treatment, the sample surface shall be no damage, deformation and other other defects.	符合要求 Meet requirement	符合 Pass

SGS 检测报告 编号 日期 第 3 页共 6 页
 Test Report No. SL520252571281TX Date: 2020-7-10 Page 3 of 6

序号 No.	检测项目及测试方法 Test Item & Test Methods	单位 Unit	技术要求 Requirement	检测结果 Test Result	单独判定 Individual Judgment
2.	头带 Mask band (GB 2626-2006 6.11)	-	固定式面罩: 10N 持续 10s, 不应出现滑脱或断裂。 For disposable face mask: Apply a tensile force of 10 N for 10 s, no slip-out, breakage occurs during the test.	未预处理 Original	符合 Pass
				后处理 After pretreatment	符合 Pass
3.	可燃性 Burning behavior (GB 2626-2006 6.15)	-	暴露于火焰的各部件应在火焰熄灭后, 不应继续燃烧, 如要继续燃烧, 燃烧时间不得超过 5s。 Where tested, the mask shall not burn or rot to continue to burn for more than 5s after removal from the flame.	未预处理 Original	符合 Pass
				后处理 After pretreatment	符合 Pass

SGS 检测报告 编号 日期 第 4 页共 6 页
 Test Report No. SL520252571281TX Date: 2020-7-10 Page 4 of 6

序号 No.	检测项目及测试方法 Test Item & Test Methods	单位 Unit	技术要求 Requirement	检测结果 Test Result	单独判定 Individual Judgment
4.	吸气阻力 Inhalation resistance (GB 2626-2006 6.3)	Pa	≤350	未预处理 Original: 177 预处理 After pretreatment: 156	符合 Pass
5.	呼气阻力 Exhalation resistance (GB 2626-2006 6.4)	Pa	≤250	未预处理 Original: 143 预处理 After pretreatment: 151	符合 Pass
6.	过滤效率 Filtration Efficiency (GB 2626-2006 6.5)	%	≥95.0	未预处理 Original: 97.216, 97.263, 97.268, 97.264, 97.259, 97.633, 98.559, 98.157, 97.500 预处理 After pretreatment: 98.555, 97.216, 97.263, 97.268, 98.544, 97.829, 97.633, 98.559, 98.157, 97.500, 98.253, 98.330, 98.542, 98.476	符合 Pass
7.	视野 Field of vision (GB 2626-2006 6.9)	%	≥1	0.7	符合 Pass
8.	视野 Field of vision (GB 2626-2006 6.10)	-	下方视野 ≥60° Lower field of vision ≥60°	61°	符合 Pass

备注: 本检测报告仅在本实验室认可范围内有效, 测试方法和标准由认证机构认可, 其 CMA 资质认定证书编号为 20021534010, 检测项目不在检测范围内, 检测项目不在检测范围内, 检测项目不在检测范围内。
 Remarks: "The test is not approved in SGS SH by China Inspection Body and Laboratory Mandatory Approval. It was carried out by Tianfangshan standardization certification & testing co., ltd and it's CMA qualification authentication license Numbers is 20021534010, the test item is not approved in the CMA's qualification authentication license."

SGS 检测报告 编号 日期 第 5 页共 6 页
 Test Report No. SL520252571281TX Date: 2020-7-10 Page 5 of 6

序号 No.	检测项目及测试方法 Test Item & Test Methods	单位 Unit	技术要求 Requirement	检测结果 Test Result	单独判定 Individual Judgment
9.	漏气 Leak (GB 2626-2006 6.4)	-	50 个动作中至少 45 个动作的 TL ≤11%, 10 个动作中至少 8 个的 TL ≤8% TL of at least 45 of 50 actions is <11%. TL of at least 8 of 10 subjects <8%	未预处理 Original: 4.57, 6.34, 6.38, 7.69, 7.65, 6.40, 7.19, 4.42, 6.38, 6.38, 6.54, 6.37 预处理 After pretreatment: 6.84, 5.45, 6.24, 7.74, 4.25, 6.50, 6.84, 6.43, 7.86, 8.18, 7.89, 7.37, 6.91, 6.66, 4.39, 4.64, 5.28, 4.30, 6.48, 6.54, 8.17, 8.19, 7.26, 7.83, 6.26, 5.20, 5.91, 5.16, 4.38, 7.69, 6.70, 6.74, 6.77, 6.12, 6.59, 7.38, 7.54, 7.52, 6.93, 6.83, 7.28	符合 Pass

SGS 检测报告 编号 日期 第 6 页共 6 页
 Test Report No. SL520252571281TX Date: 2020-7-10 Page 6 of 6

此符合声明仅基于本次实验室活动的实际情况, 本符合声明实验活动的结果不确定性影响予以考虑。
 The statement of conformity in this test report is only based on measured values by the laboratory and does not take their uncertainties into consideration.

报告结束
 "End of Report"

TEST REPORT-GB2626-2019

SGS
Test Report No. N3-20200686278 Date: 2020.7.8 Page 1 of 1

Client Information
Client Name: SoundPond
Client Address: No. 10000 Road, Tianshi Industrial Zone (F), Jiangsu Town, Wuxi City, Jiangsu Province, China
Sample Description: KNIFE-TOOTH TYPING MASK (PARTIAL) (KNIFE-TOOTH TYPING MASK (PARTIAL))

Product Information
Part No.: SP2020
Lot No.: 20200626001
Brand Name: SAFETECH
Part Type: KNIFE-TOOTH TYPING MASK (PARTIAL)

Test Method
Standard: GB 2626-2019
Test Method: KNIFE-TOOTH TYPING MASK (PARTIAL)

Author: [Signature]
Date: 2020.7.8

SGS
Test Report No. N3-20200686278 Date: 2020.7.8 Page 2 of 1

NO.	TEST ITEM & TEST METHOD	UNIT	REMARK	RESULT	UNIT	REMARK
1	Filter Efficiency (KNIFE-TOOTH TYPING MASK (PARTIAL))	%	99.9	99.9	%	Pass
2	Flow Resistance (KNIFE-TOOTH TYPING MASK (PARTIAL))	Pa	11	11	Pa	Pass
3	Leakage (KNIFE-TOOTH TYPING MASK (PARTIAL))	%	0	0	%	Pass
4	Dynamic Resistance (KNIFE-TOOTH TYPING MASK (PARTIAL))	Pa	11	11	Pa	Pass

SGS
Test Report No. N3-20200686278 Date: 2020.7.8 Page 2 of 1

NO.	TEST ITEM & TEST METHOD	UNIT	REMARK	RESULT	UNIT	REMARK
5	Filter Efficiency (KNIFE-TOOTH TYPING MASK (PARTIAL))	%	99.9	99.9	%	Pass
6	Flow Resistance (KNIFE-TOOTH TYPING MASK (PARTIAL))	Pa	11	11	Pa	Pass
7	Leakage (KNIFE-TOOTH TYPING MASK (PARTIAL))	%	0	0	%	Pass
8	Dynamic Resistance (KNIFE-TOOTH TYPING MASK (PARTIAL))	Pa	11	11	Pa	Pass

SGS
Test Report No. N3-20200686278 Date: 2020.7.8 Page 4 of 1

NO.	TEST ITEM & TEST METHOD	UNIT	REMARK	RESULT	UNIT	REMARK
9	Filter Efficiency (KNIFE-TOOTH TYPING MASK (PARTIAL))	%	99.9	99.9	%	Pass
10	Flow Resistance (KNIFE-TOOTH TYPING MASK (PARTIAL))	Pa	11	11	Pa	Pass
11	Leakage (KNIFE-TOOTH TYPING MASK (PARTIAL))	%	0	0	%	Pass
12	Dynamic Resistance (KNIFE-TOOTH TYPING MASK (PARTIAL))	Pa	11	11	Pa	Pass

SGS
Test Report No. N3-20200686278 Date: 2020.7.8 Page 4 of 1

NO.	TEST ITEM & TEST METHOD	UNIT	REMARK	RESULT	UNIT	REMARK
13	Filter Efficiency (KNIFE-TOOTH TYPING MASK (PARTIAL))	%	99.9	99.9	%	Pass
14	Flow Resistance (KNIFE-TOOTH TYPING MASK (PARTIAL))	Pa	11	11	Pa	Pass
15	Leakage (KNIFE-TOOTH TYPING MASK (PARTIAL))	%	0	0	%	Pass
16	Dynamic Resistance (KNIFE-TOOTH TYPING MASK (PARTIAL))	Pa	11	11	Pa	Pass

SGS
Test Report No. N3-20200686278 Date: 2020.7.8 Page 4 of 1

NO.	TEST ITEM & TEST METHOD	UNIT	REMARK	RESULT	UNIT	REMARK
17	Filter Efficiency (KNIFE-TOOTH TYPING MASK (PARTIAL))	%	99.9	99.9	%	Pass
18	Flow Resistance (KNIFE-TOOTH TYPING MASK (PARTIAL))	Pa	11	11	Pa	Pass
19	Leakage (KNIFE-TOOTH TYPING MASK (PARTIAL))	%	0	0	%	Pass
20	Dynamic Resistance (KNIFE-TOOTH TYPING MASK (PARTIAL))	Pa	11	11	Pa	Pass

SGS
Test Report No. N3-20200686278 Date: 2020.7.8 Page 7 of 1

Product Description
The sample is KNIFE-TOOTH TYPING MASK (PARTIAL). The test results are as follows:

- Filter Efficiency: 99.9% (Pass)
- Flow Resistance: 11 Pa (Pass)
- Leakage: 0% (Pass)
- Dynamic Resistance: 11 Pa (Pass)



Product photograph showing the KNIFE-TOOTH TYPING MASK (PARTIAL) samples being tested.



DUST- AND GERM-FREE WORKSHOP

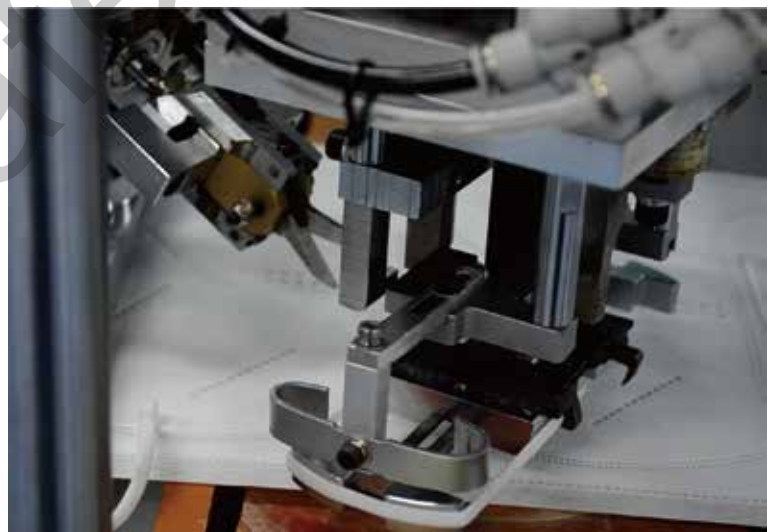

TESTING LABORATORY



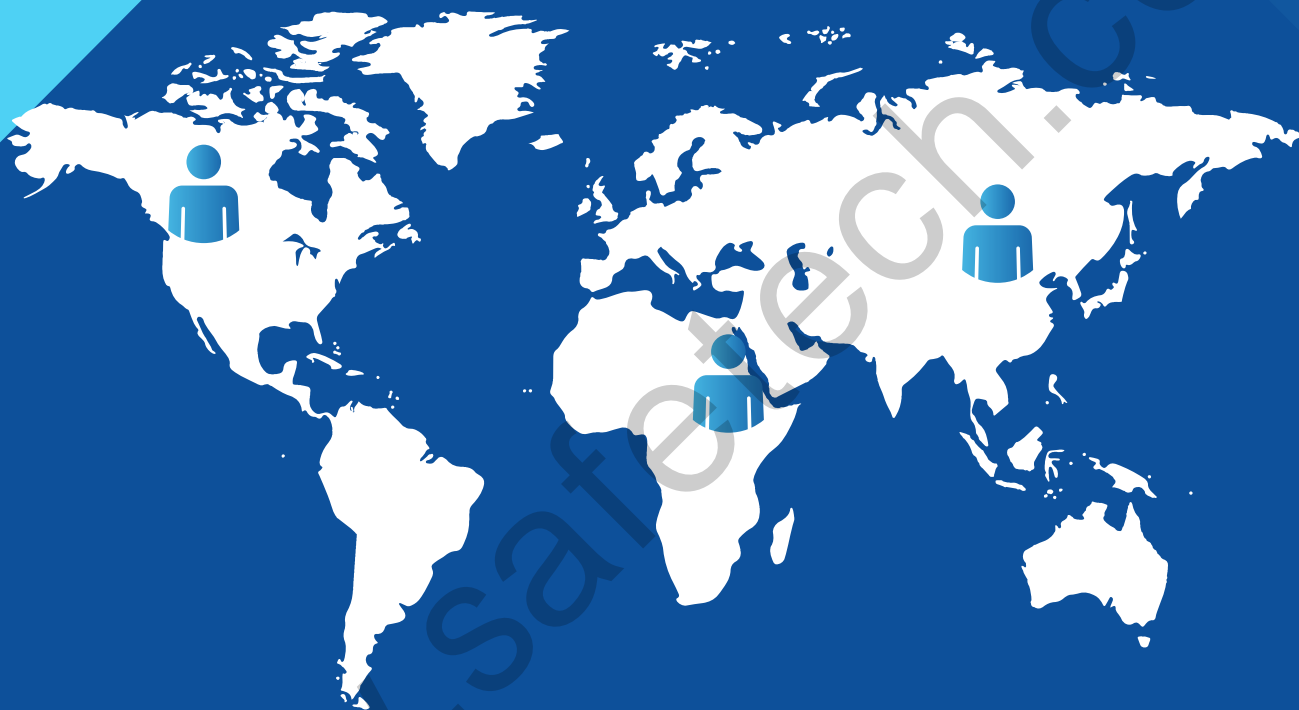

**SOUNDPOND INTERNATIONAL CO.,LTD
FUJIAN SAFETECH PROTECTION CO.,LTD
GREAT UNION GARMENT MFG.LIMITED**

ADDRESS: NO.6 ROAD EAST,TIELING INDUSTRIAL ZONE,ZONE 1,
BLOCK 9 JINGXI TOWN.MINHOU COUNTY FUZHOU,
FUJIAN PROVINCE,P.R.CHINA

FAX.: +86-591-8782 6099

TEL.: +86-591-8780 7888

WEB: [HTTP://WWW.SPSAFETECH.COM](http://www.spsafetech.com)

E-MAIL: INFOSAFETECH@SPSAFETECH.COM

FUZHOU · CHINA